EE273 Lecture 5

Signal Return Crosstalk, Inter-Symbol Interference, Managing Noise

January 29, 2001

William J. Dally
Computer Systems Laboratory
Stanford University
billd@csl.stanford.edu

Today's Assignment

- Reading
 - Sections 7.1 and 7.3
 - Complete before class on Wednesday 1/31

A Quick Overview

- Signal Return Crosstalk
 - current on shared return lines causes interference between signals
 - large numbers of signals switching simultaneously may result in significant noise
- Inter-Symbol Interference
 - some transmission systems *remember* their history
 - residual state from previous bits may distort the current bit
 - reflections on transmission lines
 - resonant circuits
 - slow rise times
- Managing Noise
 - divide noise along two axes
 - proportional vs. independent
 - bounded vs. statistical
 - prepare a budget for the bounded sources
 - net margin is what remains after bounded sources
 - compare magnitude of net margin to standard deviation of statistical sources
 - the bit-error rate is a function of this signal-to-noise ratio (SNR)

Signal Return Crosstalk

- With *single-ended* signals return currents from several signals often share paths
- Suppose N drivers share a path with parasitic inductance L_R
- Each driver switches current i in time t_r .
- If all but one output switch simultaneously noise is $(N-1)Ldi/dt$
- Need a large number of return paths to operate at high speed

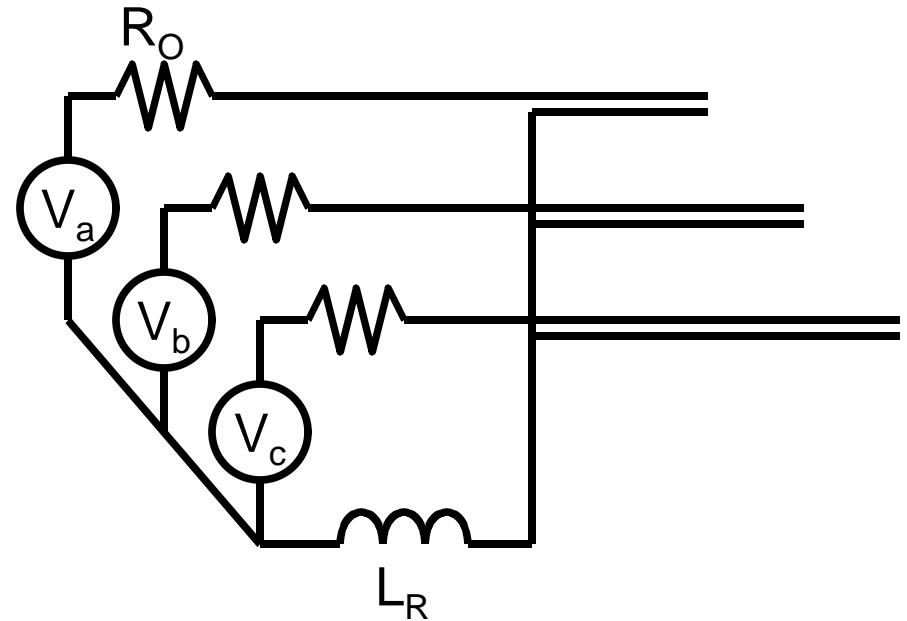

- Closely related to power supply cross talk
- Also called “ground-bounce” and “simultaneous switching output (SSO)” noise.

Example Calculation

- $L_R = 5\text{nH}$
- $i = 10\text{mA}$
- $t_r = 200\text{ps}$
- $di/dt = 5 \times 10^7$
- $L di/dt = 0.25\text{V}$
- $V_{RXN} = (N-1)L di/dt$
 $= 0.25(N-1)\text{V}$

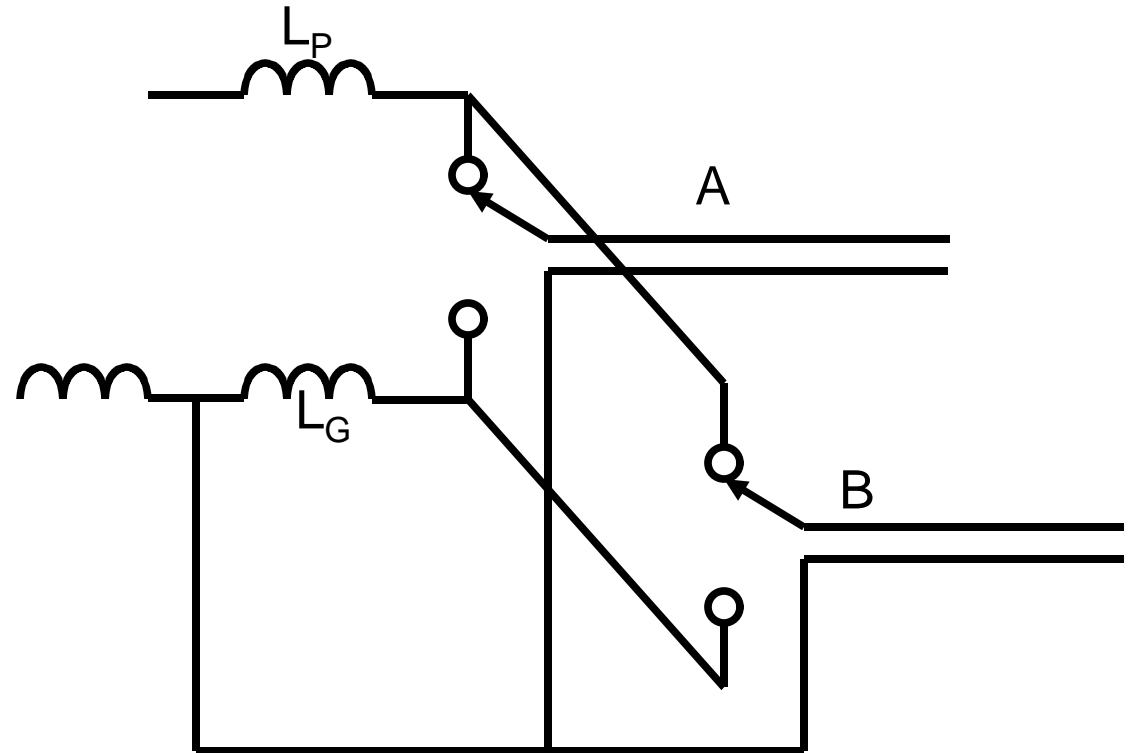

Return Crosstalk and Rise Time

- Return crosstalk is inversely proportional to rise time for *resistive* loads (transmission lines)
- Return crosstalk is inversely **quadratic** with rise time for capacitive loads
- Noise can be greatly reduced by slowing down the signal edge (not the clock cycle)

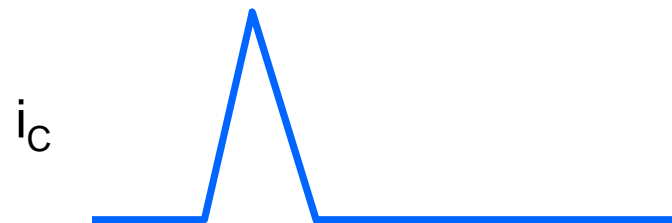
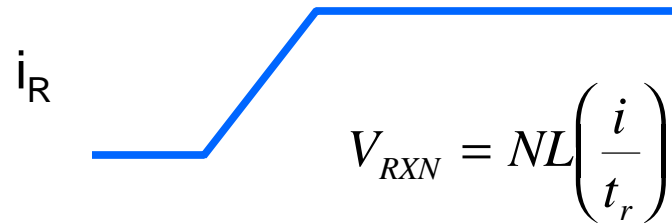

$$Q = CV = \frac{it_r}{2}$$

$$V_{RXN} = NL \left(\frac{4CV_s}{t_r^2} \right)$$

Intersymbol Interference

- Ideally a transmission system is *memoryless*
 - no history of previous bits
- In reality, the state of the system is affected by previous bits
 - reflections on transmission lines
 - magnitude and phase of excited resonances
 - signals that don't reach the *rails* by the end of the cycle
- This history affects the transmission of the current bit

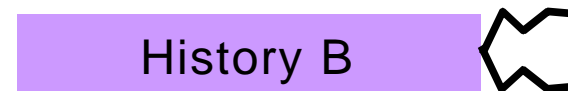

Impedance Mismatches

- *Echos* of previous bits reflect up and down transmission lines
- A mismatch of x gives (to first order) a reflection of $k_R = x/2$
- Worst-case superposition of entire echo train is

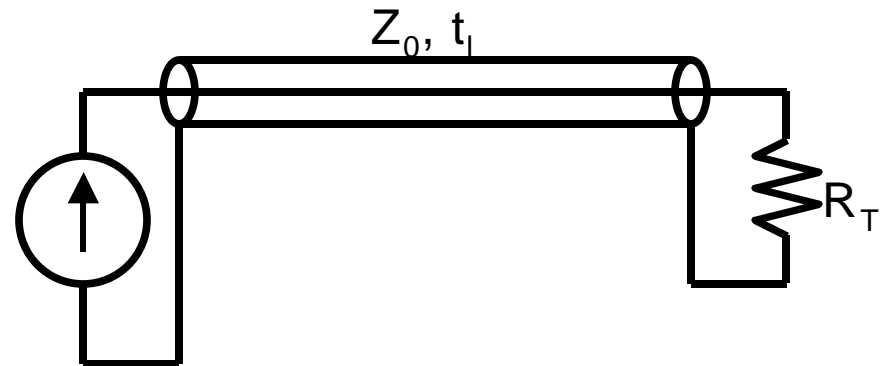

$$k_{ir} = \sum_{i=1}^{\infty} k_R^i = \frac{k_R}{1 - k_R}$$



Resonant Circuits

- Tank circuits and resonant sections of transmission lines oscillate
- Oscillations are excited by signal transitions and may interfere with later transitions
- Slow rise times pump less energy into resonant circuits
- Resistance damps oscillation

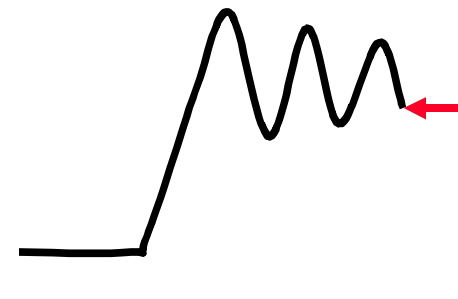
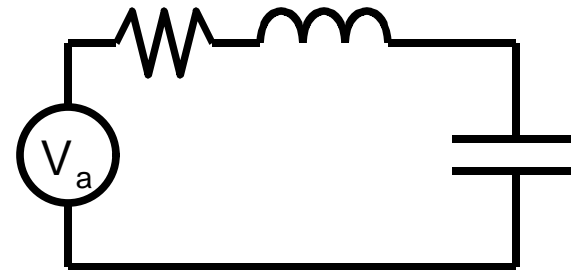

Next bit starts from
history-dependent state

Inertial Delay

- Some circuits don't reach steady-state by the end of the cycle
- Start of the next bit then depends on history
 - residual voltage
- Leads to both voltage and timing noise
- Often caused by poor design for rise-time control

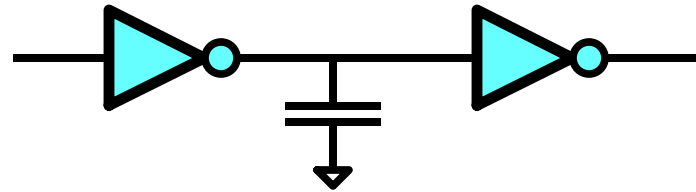

Other Noise Sources

- Alpha particles
 - 5MeV particle injects 730fC of charge into substrate
 - One node typically collects less than 50fC
- Thermal (Johnson) and Shot noise
 - Proportional to bandwidth – typically in the μV
- Parameter mismatch
 - V_T and β have deviation proportional to $1/\sqrt{WL}$
 - Systematic variations depend on layout

Managing Noise

- We manage noise using noise budgets
- Categorize noise along two axes
 - proportional vs. independent
 - bounded vs. statistical
 - Some noise sources could go in either category (e.g., crosstalk to perpendicular lines)
- Allocate noise to various sources
- Constrain design to meet the budget

	Proportional	Independent
Bounded	Parallel Xtalk ISI	Rcvr Offset Rcvr Sens.
Statistical	Perp. Xtalk	PS Noise Thermal Noise

The Noise Budget

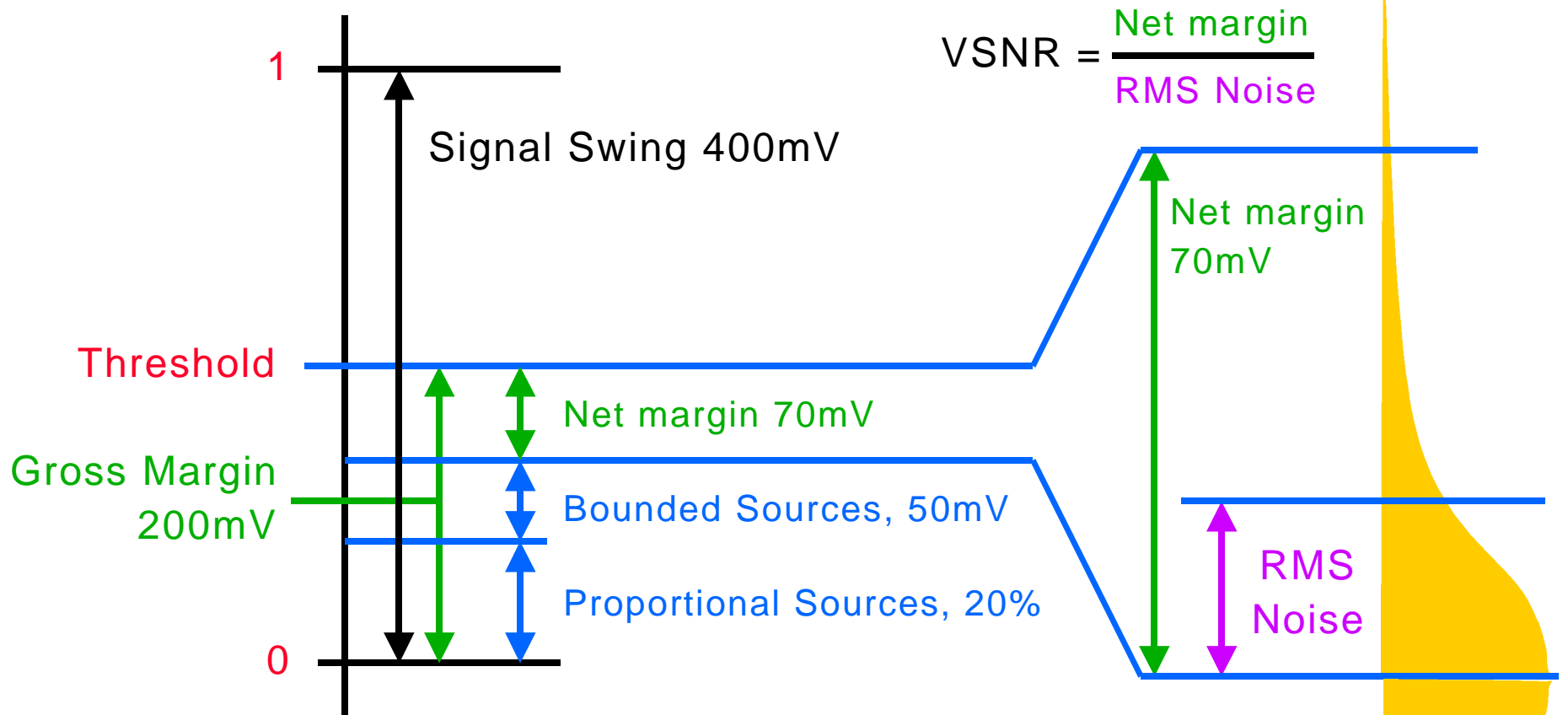

Worst-Case Analysis

- Noise sources are an unknown
- With worst-case analysis, assume
 - all noise sources have the greatest possible magnitude
 - they all sum up in the same direction
- Unlikely in any single unit at any instant in time but...
 - if you make enough units
 - and run them long enough
 - this case will occur

Signal Swing		400	mV
Vni	Rcvr off+sense	50	mV
	Uncancelled PS noise	20	mV
	TOTAL Vni	70	mv
Kn	Crosstalk	0.1	
	Reflections	0.1	
	TOTAL Kn	0.2	
	KnVs	80	mV
	Gross Margin	200	mV
	Vni	70	mV
	KnVs	80	mV
	Vn	150	mV
	Net Margin	50	
	Margin Ratio	0.25	

Margins and Margin Ratio

- Gross margin is half the signal swing, V_{GM}
- Net margin is gross margin less all bounded noise sources, V_{NM}
- Margin ratio: V_{NM}/V_{GM} is a good figure of merit
 - indicates proportion by which you can increase noise sources without causing failure
- Total noise margin is meaningless
- Data sheets report gross margin less receiver offset+sensitivity

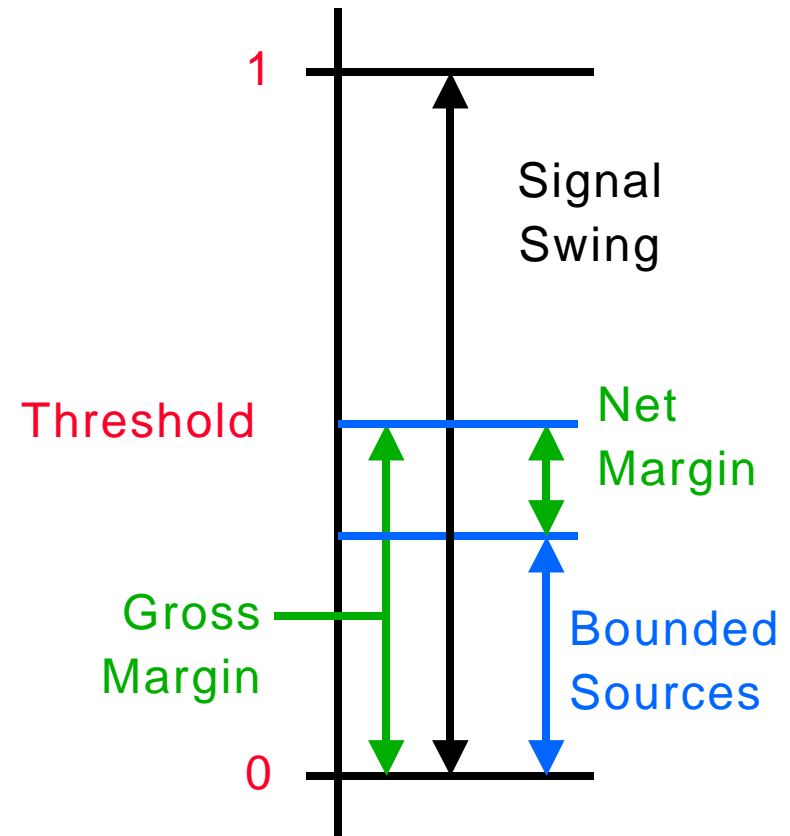

Statistical Analysis

Gaussian Noise and Bit-Error Rate

- For some noise sources we consider the probability distribution of values rather than the worst-case value
 - truly random noise sources
 - thermal noise, shot noise
 - uncorrelated bounded noise sources
 - crosstalk, power supply noise
- Typically we model these sources with a Gaussian distribution
- Most sources are zero mean
- The relevant parameter is their standard deviation or *root-mean-squared* (RMS) value

Adding Gaussian Noise Sources

- To sum up zero-mean Gaussian noise sources
 - sum the variance, not the standard deviation
- A 10mV RMS source added to a 20mV RMS source gives a 22.4mV RMS source

$$V_{RMS} = \left(\frac{1}{N} \sum V_i^2 \right)^{1/2}$$

Crosstalk	10.0	mV (RMS)
PS Noise	20.0	mV (RMS)
TOTAL	22.4	mV (RMS)

Gaussian Distribution and Error Function

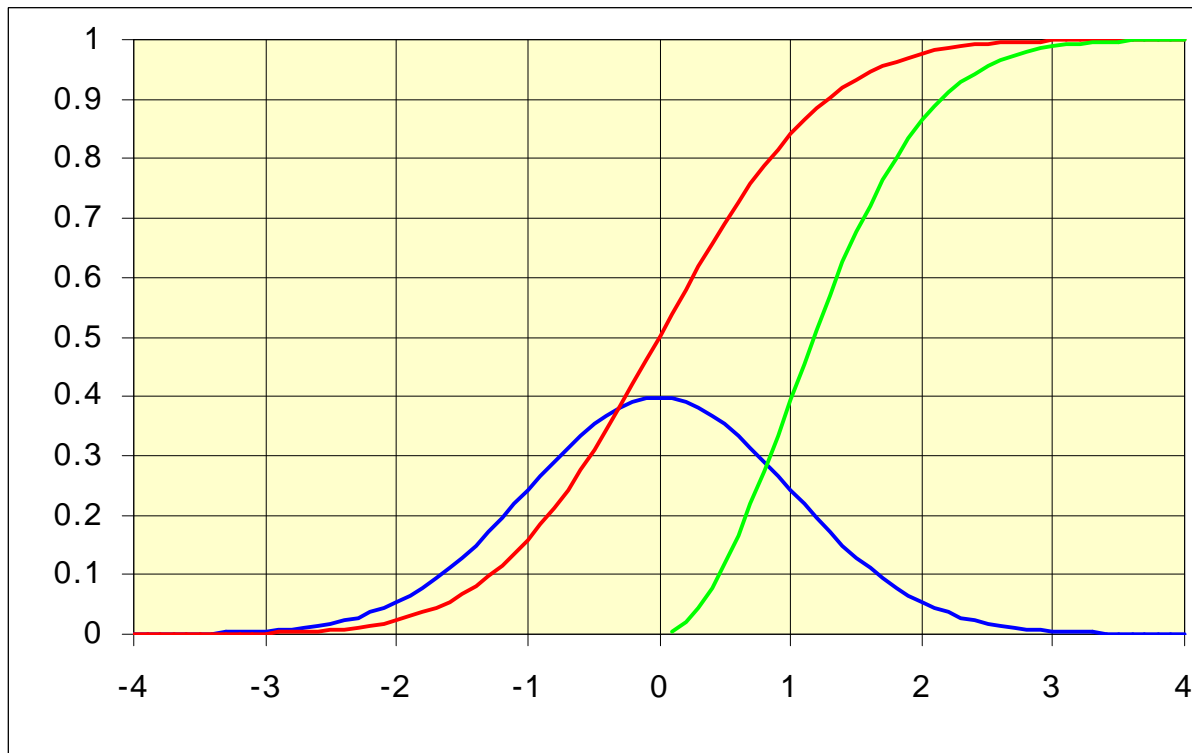

$$P(x) = \frac{1}{\sqrt{2p}} \exp\left(-\frac{x^2}{2}\right)$$

$$\text{erf}(x) = \int_{-\infty}^x P(y) dy$$

$$1 - \text{erf}(x) > \exp\left(\frac{-x^2}{2}\right)$$

Bit Error Rate (BER)

- If the *net margin* is V_{NM}
- and the total gaussian noise is V_{GN}
- The Gaussian signal to noise ratio is
$$VSNR = V_{NM}/V_{GN}$$
- What is the probability that the noise will exceed the margin?

$$P(\text{error}) = 1 - \text{erf}\left(\frac{V_{GN}}{V_{NM}}\right)$$
$$< \exp\left(-\frac{1}{2}\left(\frac{V_{GN}}{V_{NM}}\right)^2\right)$$

Error Function vs. Exponential

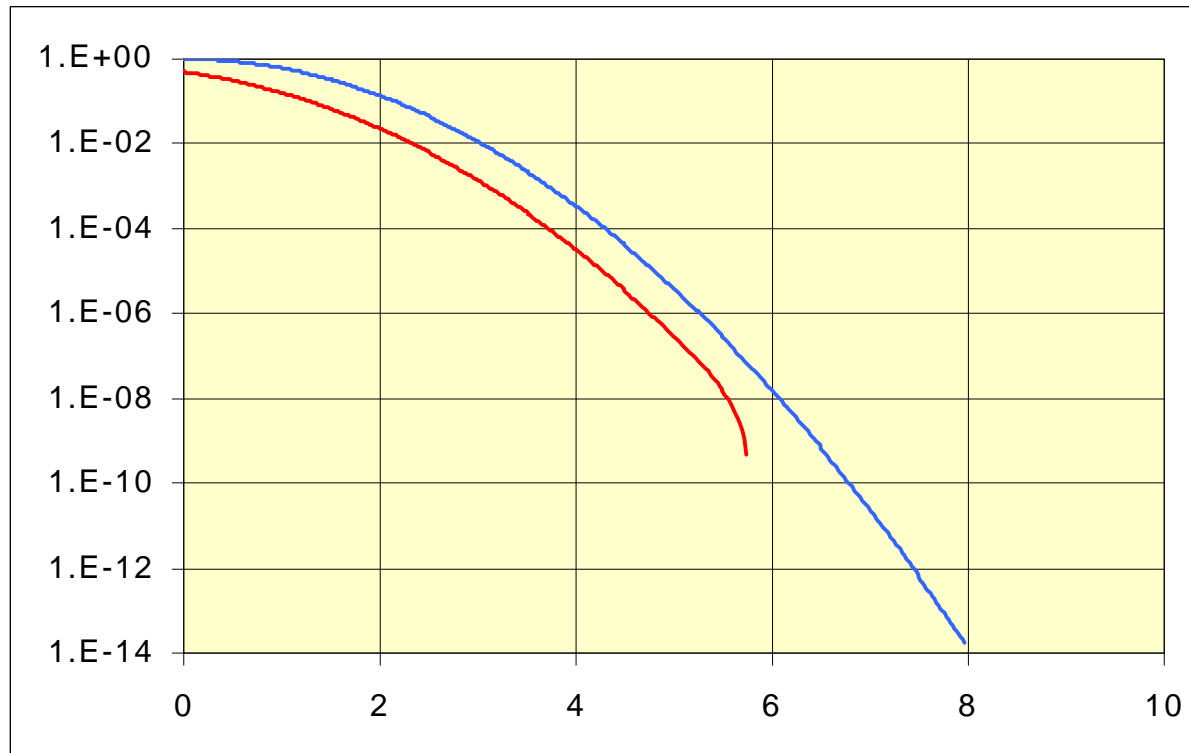

$$P(\text{error}) = 1 - \text{erf}\left(\frac{V_{GN}}{V_{NM}}\right)$$
$$< \exp\left(-\frac{1}{2}\left(\frac{V_{GN}}{V_{NM}}\right)^2\right)$$

An Example Noise Calculation

- 250mV differential signal
- 15% high-frequency attenuation
- 5% crosstalk from adjacent lines
- 5% ISI from reflections
- 20mV receiver offset+sensitivity
- 10mV RMS perpendicular crosstalk
- 10mV RMS 'other' noise
- What is the Bit Error Rate?

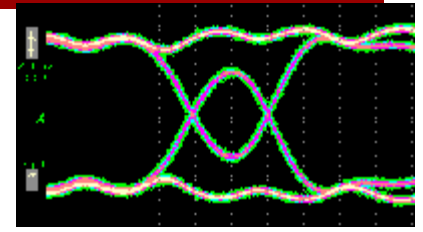
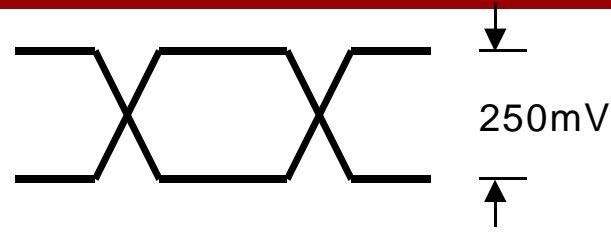

	K	mV
Signal Swing (dp-dn)		500
Gross Margin		250
Crosstalk	0.1	25
Reflections	0.1	25
Attenuation	0.2	75
KN	0.3	125
Receiver offset+sensitivity		20
Fixed noise		145
Net Margin		105
Perpendicular Crosstalk		10
Other Noise		10
Total Gaussian		14.1
VSNR		7.4
BER		1.07E-12

Noise Budgets and Design Rules

- Do we do a noise budget for every signal?
 - Of course not
- Noise budgets are done for classes of signals that obey a set of design rules or ground rules
 - board to board signals
 - intra-board signals (chip-to-chip)
 - global on-chip signals
 - local on-chip signals
 - special signals (e.g., domino or RAM bit lines)
- For each class of signals a set of rules constrains the signal to meet the noise budget
 - line geometry and spacing
 - maximum parallel length
 - ground shields
 - impedance and termination tolerance
 - driver and receiver specifications
- If each signal meets these specs you know it meets the budget and hence will have a BER at least as good as calculated!

Next Time

- Signaling
- Current-mode and voltage-mode transmission
- References
- Termination