

6-3

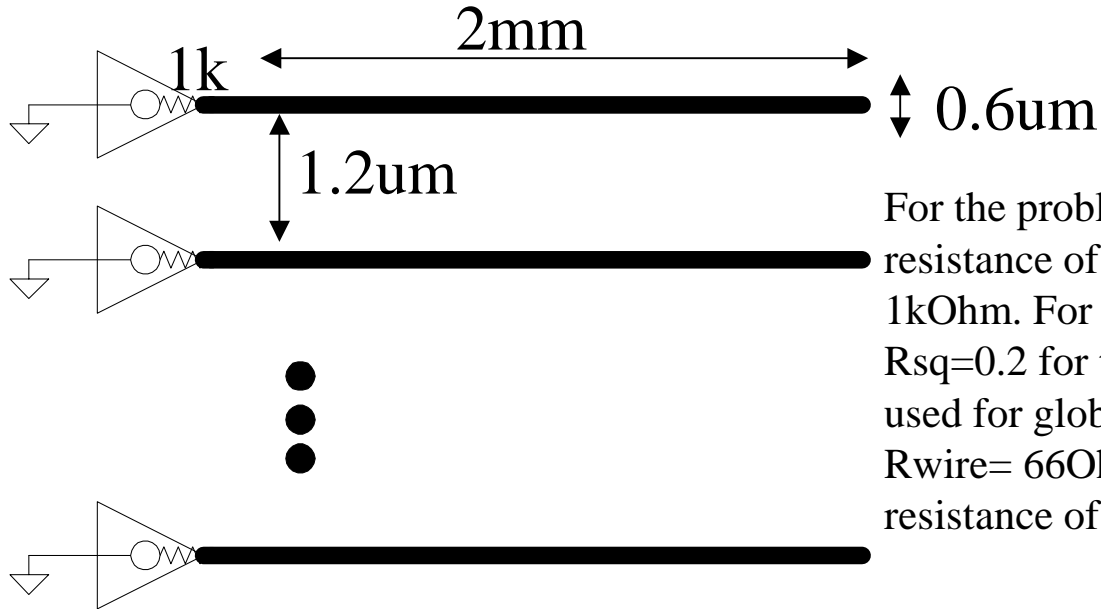

For the problem, you can approximate that the resistance of the wires will be smaller than 1kOhm. For example, in 0.35um process, $R_{sq}=0.2$ for top level metal, probably to be used for global interconnect. In this case, $R_{wire}= 66\text{Ohms} \ll 1\text{kOhms}$. So, ignore the resistance of the wire for this problem.

Using Table 6-2,

Line a

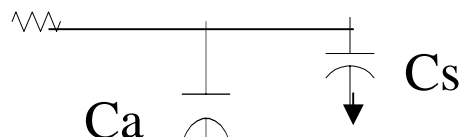

$$C_s = \text{Cap}(\text{top}) + \text{Cap}(\text{bottom}) = 2 * (2\text{mm} * 0.05\text{fF}/\mu\text{m}^2) = 200\text{fF}$$

Line b

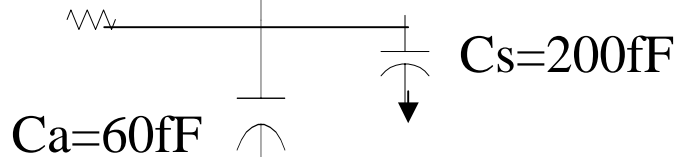

$$C_a = \text{Cap}(\text{side}) = 0.03\text{fF}/\mu\text{m} * 2\text{mm} = 60\text{fF}$$

Line c

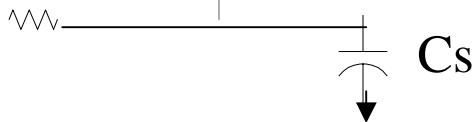

6-3(contd)

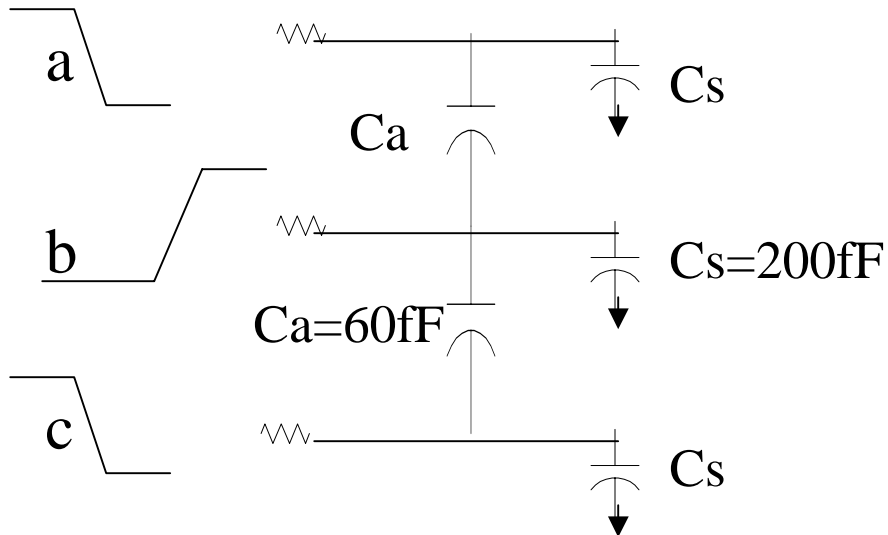

What is the worst case condition of transitions which will cause the maximum delay? Obviously, if the two side aggressor lines (a and c) transition in the opposite direction of the main driver line (b), this will create the most amount of capacitance for the driver line to switch. Due to the Miller effect, line B will see approximately twice the capacitance from both lines A and C

$$C(\text{total}) \text{ on line b} = C_s + 2 * C_a(\text{line a}) + 2 * C_a(\text{line c}) \\ = 440\text{fF}$$

For resistance = 1k, Time Constant $\tau =$

$$R * C_{\text{tot}} = 440\text{ps}$$

Obviously, for the best case delay, the aggressor lines (a and c) switch in the same direction as line b. In this case the capacitance = 200ff.

$$R * C_{\text{tot}} = 200\text{ps}$$

6-6

The crosstalk coefficient calculations are shown in the spreadsheet.

The problem is solved using superposition. The transmission lines present an even mode impedance Z_{even} when only the even mode voltage sources are active. Similarly each of the lines has the odd mode impedance Z_{off} when the odd mode voltage sources are active. I_{even} is the even mode current, I_{odd} the odd mode current.

For the far end, the even and odd mode responses arrive at different time, since the velocities for the two modes are different. For the line Q, the odd mode response is negative and arrives earlier while the even mode response is positive and arrives later

We use 1V voltage sources, because initially, we assume we know nothing about the transmission line, except that it is nominally 63 ohms, and we need to get +0.5V even mode waves down both A and NE, and +0.5V wave down A and a -0.5V wave down NE.

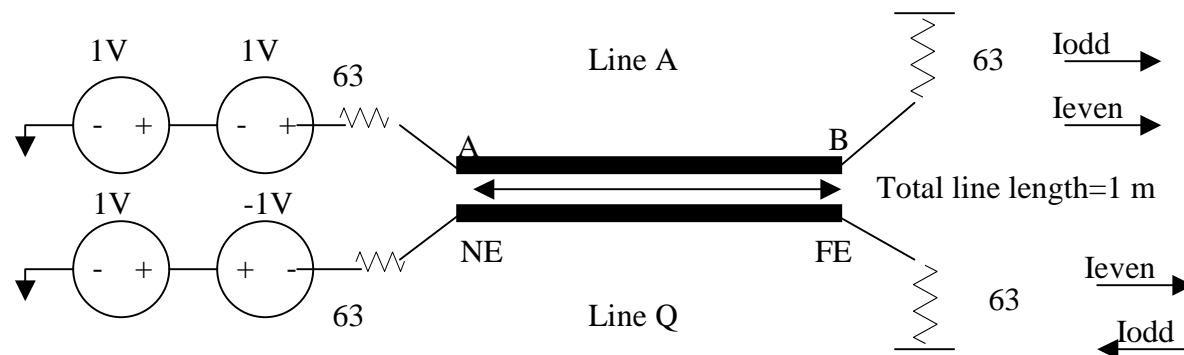

To find the near end crosstalk coefficient, calculate what the magnitude of the waves are at points A and points NE.

$$V_a(\text{even}) = \frac{1V * Z_0(\text{even})}{63 + Z_0(\text{even})} = 0.5298V$$

$$V_a(\text{odd}) = \frac{1V * Z_0(\text{odd})}{63 + Z_0(\text{odd})} = 0.4706V$$

$$V_a(\text{total}) = V_a(\text{even}) + V_a(\text{odd}) = 1V$$

$$V_{ne}(\text{even}) = \frac{1V * Z_0(\text{even})}{63 + Z_0(\text{even})} = 0.53V$$

$$V_{ne}(\text{odd}) = \frac{-1V * Z_0(\text{odd})}{63 + Z_0(\text{odd})} = -0.47V$$

$$V_{ne}(\text{total}) = V_{ne}(\text{even}) + V_{ne}(\text{odd}) = 0.059V \text{ (same as in table)}$$

$$K_{rx}(\text{near end cross talk}) = V_a(\text{total}) / V_{ne}(\text{total}) = 0.059V$$

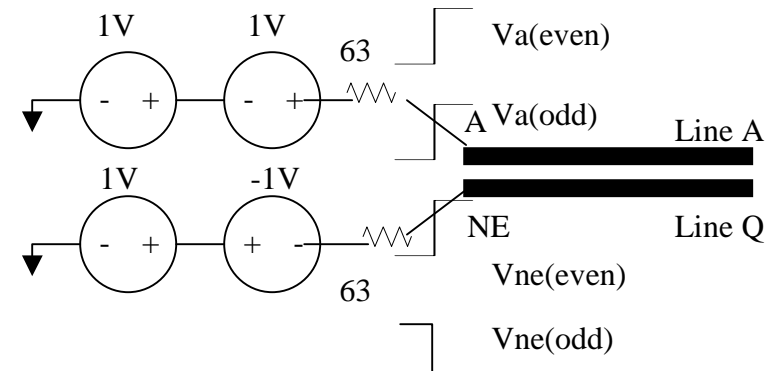

For the far end of the line, we now need to worry about the speed of flight. Since we are using a stripline arrangement, as described in the book, the dielectric medium is not symmetric.(there is air on the top side). This causes the different modes, even and odd, to travel at different speeds down the line. So first we need to calculate the speed of the even and odd modes.

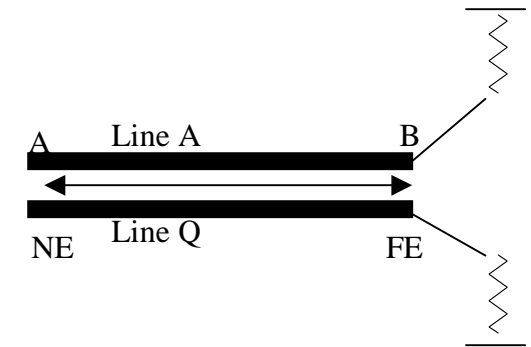

Velocity(even)= 1.7e8 m/s (see table on next page)

Velocity(odd) = 1.9e8 m/s

Tcoupling(even)= 5.8ns

Tcoupling(odd) = 5.3ns

This shows that the odd mode wave travels down the transmission line faster than the even mode. Basically, because of the different velocities, you will see the odd mode hit the line, followed by the even mode cancelling this voltage.

From the figure 6-12, you can estimate from a linear model the magnitude of far end crosstalk as $V_{fe} = \frac{K_{fs} * t_x}{trise}$

Where $t_x = T_{coupling(odd)}$, since this is the only wave that matters in the determining the front portion of the far end crosstalk.

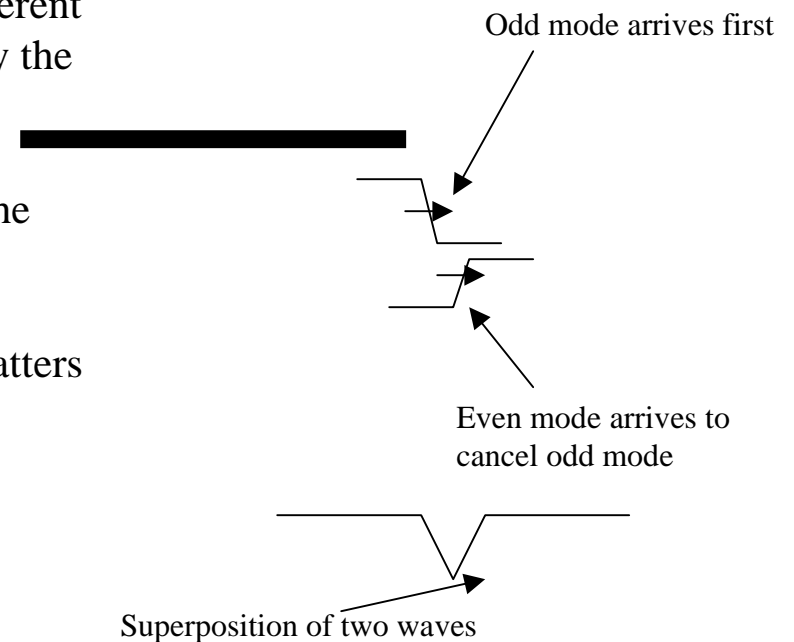

$$V_{fe}(\text{odd}) = V_{ne}(\text{odd}) * [1 + K_{fe}(\text{odd})]$$

$$K_{fe}(\text{odd}) = \frac{63-56}{63+56} = 0.059$$

$$V_{fe}(\text{odd}) = -0.47 * [1 + 0.059] = -0.498V$$

$$V_{fe} = \frac{K_{fe} * t_x}{trise} \rightarrow K_{fe} = \frac{V_{fe} * trise}{t_x} = -0.047, \text{ where } trise = 500ps$$

Let's find out the what happens when the even mode wave hits the far end of the line.

$$V_{fe}(\text{even}) = V_{ne}(\text{even}) * [1 + K_{fe}(\text{even})]$$

$$K_{fe}(\text{even}) = \frac{63-71}{63+71} = -0.0597$$

$$V_{fe}(\text{even}) = 0.53V * [1 + -0.0597] = 0.0498V$$

So, after both the odd and even portions of the wave arrive at the far end, the magnitude = 0 [V_{fe}(odd) + V_{fe}(even)], which is what you would expect.

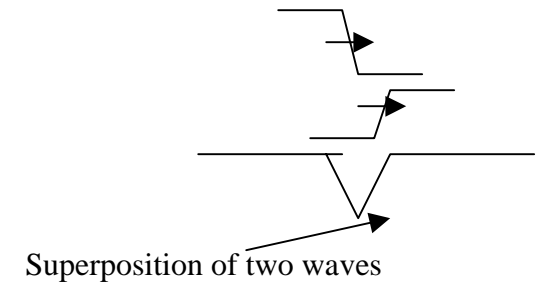

L	355nH
M	57.5nH
C	88pF
Cm	6.4pF
Zo	63 Ohms
Z(odd) $\sqrt{(L-M)/(C+Cm)}$	56 Ohms
Z(even) $\sqrt{(L+M)/(C-Cm)}$	71 Ohms
Near End Crosstalk Coefficient	
$I_{even} = 1V / (Z_{even} + Z_o)$	7.4mA
$I_{odd} = 1V / (Z_{odd} + Z_o)$	8.4mA
$V_{even} = Z_{even} * I_{even}$	0.53V
$V_{odd} = -I_{odd} * Z_{odd}$	0.47V
$V_a = V_{even} + V_{odd}$	1V
$V_{ne} = V_{even} - V_{odd}$	0.059
$K_x(\text{near end}) = V_{ne} / V_a$	0.059
Far End Crosstalk Coefficient	
$Velocity(\text{even}) = 1 / \sqrt{(L+M)(C-Cm)}$	1.7e8 m/s
$Velocity(\text{odd}) = 1 / \sqrt{(L-M)(C+Cm)}$	1.9e8 m/s
Trise(given)	500ps
$T_{even} = 1m / Velocity(\text{even})$	5.80E-09
$T_{odd} = 1m / Velocity(\text{odd})$	5.30E-09
$K_r(\text{even}) = (Z_o - Z_{even}) / (Z_{even} + Z_o)$	-0.0563
$K_r(\text{odd}) = (Z_o - Z_{odd}) / (Z_{odd} + Z_o)$	0.062
$V_{fe}(\text{even}) = V_{even} * (1 + K_r(\text{even}))$	0.498
$V_{fe}(\text{odd}) = V_{odd} * (1 + K_r(\text{odd}))$	-0.498
$K_{fe}(\text{even}) = V_{fe}(\text{even}) * Trise / T_{even}$	0.043
$K_{fe}(\text{odd}) = V_{fe}(\text{odd}) * Trise / T_{odd}$	-0.047

6-9

Typically, in a silicon integrated circuit, there are some significant parasitics due to the signal pads as well as the bond wire which attaches to the outside package.

Each CMOS die has many signals which are connected with the outside world(package) using square signal pads(I.e. 80um x 80um) which allow the designer to attach bond wires from the package to the IC.

Each signal pad adds some capacitance(I.e. 2pF) to the substrate(ground), while each signal bond wire provides some inductance.(typically, 1nH/mm). I.e. 5nH.

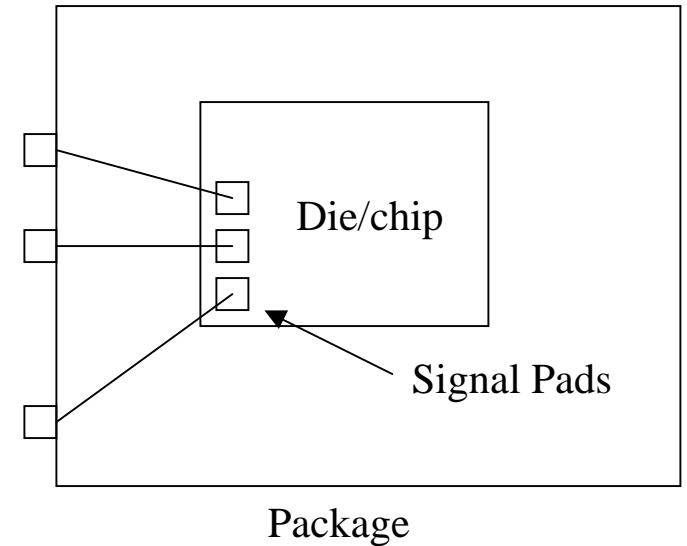
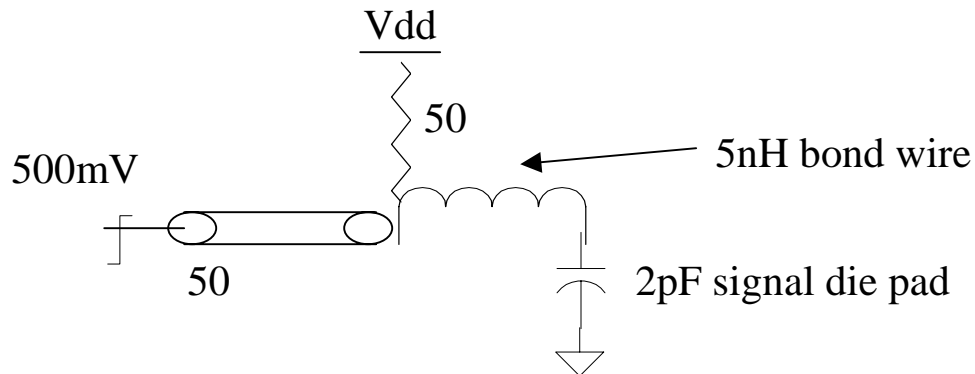

Since we are doing a parallel termination, at the die side, a termination of 50 ohms to Vdd is seen, terminating the 50 ohm transmission line. Effectively, we see a 500mV pulse being applied to an LC tank, with a dissipative tank impedance of 25 Ohms.

From 6-24, $K_x = \exp(-t_b \cdot R/2L)$ $L=5\text{nH}, R=25\text{ Ohms}, t_b=2\text{ns}$

$\rightarrow K_x=6.73\text{e-}3$

$K_{ix} = \dots = \frac{K_x}{1 - K_x}$

$K_{ix}=6.8\text{e-}3$, Therefore, for a 500mV pulse, the worst case ISI will be $6.8\text{e-}3 \cdot 500\text{mV}=3.39\text{mV}$

$$6-16 \quad \text{BER} \leq \exp(-V_{\text{snr}}^2 / 2)$$

$$\text{case 1: } 1e-8 \leq \exp(-V_{\text{snr1}}^2 / 2) \quad \text{Where } V_{\text{snr1}} = \frac{\Delta V / 2 - V_n}{\sqrt{V_{r0}^2 + V_{r1}^2}}$$

$$\text{case 2: } 1e-4 \leq \exp(-V_{\text{snr2}}^2 / 2) \quad \text{Where } V_{\text{snr2}} = \frac{\Delta V / 2 - V_n}{\sqrt{V_{r0}^2 + V_{r2}^2}}$$

Where $\Delta V = 500\text{mV}$, V_{r0} =Gaussian noise of the channel before added noise, $V_{r1}=15\text{mV}$, $V_{r2}=25\text{mV}$.

We now have two equations with two unknowns.

$$V_{\text{snr1}}=6.07 \quad V_{\text{snr2}}=4.3$$

$$6.07 = \frac{250\text{mV} - V_n}{\sqrt{V_{r0}^2 + 0.015^2}} \quad 4.3 = \frac{250\text{mV} - V_n}{\sqrt{V_{r0}^2 + 0.025^2}}$$

Solving for V_n and V_{r0} ,

$$V_{r0}=13.2\text{mV}, \quad V_n = 128\text{mV}$$

$$\text{BER with no added noise} \rightarrow \text{BER} = 4.3e-19$$

The number above may vary within an order of magnitude, due to the exponential characteristic.

Lecture Notes Problem

Signal Swing(dp-dn)		500
Gross Margin		250
Crosstalk	0.05	25
Reflections	0.05	25
Attenuation	0.15	75
KN	0.25	125
Receiver offset+sensitivity		20
Bounded Noise		145
Net Margin		105
Gaussian Noise		10
VSNR		10.5
BER		1.15E-24

1. A. What should the signal swing be for BER < 1e-9?

$$\text{BER} < \exp(-V_{\text{snr}}^2/2) = 1e-9$$

$$V_{\text{snr}} = 6.44 \rightarrow V_r=10\text{mV}, \rightarrow V_m = 64.4\text{mV}$$

→ $V_m = \Delta V/2 - V_n(\text{total})$, ΔV is the signal swing we are solving for, and V_n is the total noise(fixed and proportional noise sources)

$$\rightarrow V_n(\text{total})=V_n(\text{fixed}) + V_n(\text{proportional})$$

$$\rightarrow V_n(\text{fixed}) = 20\text{mV}$$

$$\rightarrow V_n(\text{proportional})= \Delta V(0.05+0.05+0.15)=0.25* \Delta V$$

$$64.4\text{mV} = \Delta V/2 - 0.25* \Delta V - 20\text{mV}$$

$$\rightarrow \Delta V = 338\text{mV}$$

1. B. For BER < 1e-12?

$$V_{\text{snr}} = 7.43 \rightarrow V_r=10\text{mV}, \rightarrow V_m = 74.3\text{mV}$$

From the same analysis as above, $\Delta V = 377\text{mV}$

Notice how fast the BER changes for small increases in signal swing.

2. What if the receiver offset+sensitivity is now 60mV?
 What is the new BER?(assuming 500mV swing)

Signal Swing(dp-dn)		500
Gross Margin		250
Crosstalk	0.05	25
Reflections	0.05	25
Attenuation	0.15	75
KN	0.25	125
Receiver offset+sensitivity		60
Bounded Noise		185
Net Margin		65
Gaussian Noise		10
VSNR		6.5
BER		7.00E-10

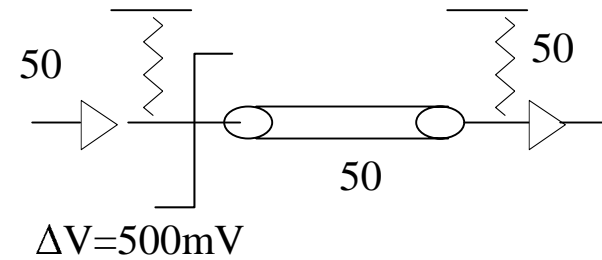

Question: There are two possible setups for serial links on the right:
Parallel termination and source termination.

Design a noise analysis table (I.e. noise margin/BER table) for the
Two possible setups.

Here are the pertinent details:

1. The transmitter uses current mode logic and switches 10mA of current.
2. The attenuation of the line is 15%
3. Each termination resistor is mismatched from the 50 Ohm transmission line by 20%
4. This is a homogenous medium, so the $K_{fx}=0$
5. Near End crosstalk, $K_{rx}=15\%$... Assume the victim and aggressor lines are transmitting data in the same direction (I.e. from left to right)
6. Receiver offset+sensitivity = 20mV
7. Gaussian Noise = 10mV
8. Ignore all reflections which take more than two round trips. Make any approximations.
9. Assume there is only one victim and one aggressor signal lines.

Note: you can assume either 10mA or 20mA for the solution to the problem.
This solution uses 10mA. Also, the resistor terminations do not affect the value of the launched wave onto the line.

A. Parallel Termination

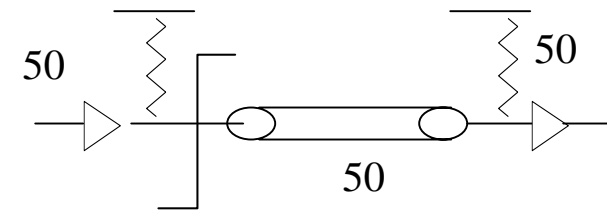

B. Source Termination

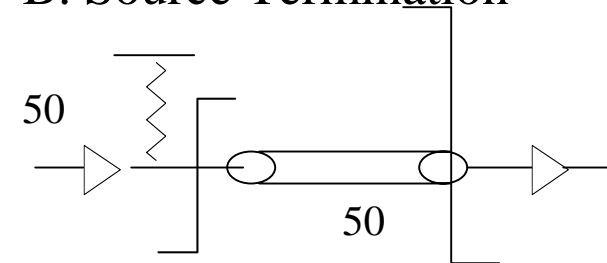

Signal Swing(at transmitter)		250
Signal Swing(at receiver)		212.5
Gross Margin(at receiver)		106
Crosstalk		12.8
Reflections	0.1	21
Receiver offset+sensitivity		20
Bounded Noise		53.8
Net Margin		52.2
Gaussian Noise		10
VSNR		5.22
BER		1.21E-06

A. Parallel Termination

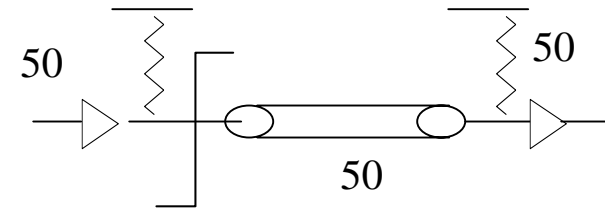

Signal Swing

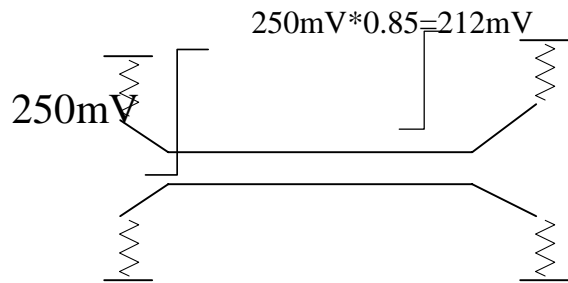

Reflections

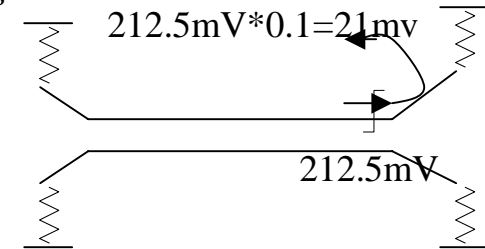

Crosstalk

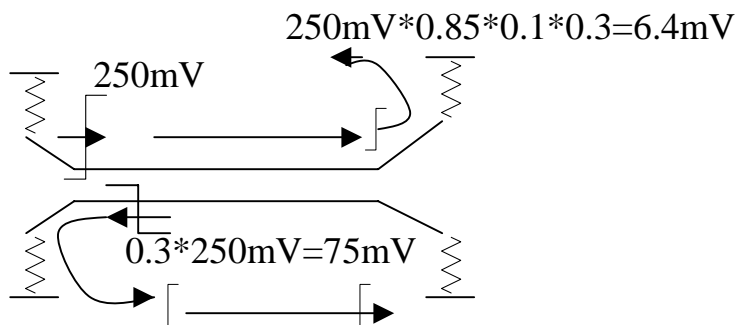

$0.1 * 0.3 * 250\text{mV} = 7.5\text{mV}$ $7.5\text{mV} * 0.85 = 6.4\text{mV}$
 (total crosstalk is $6.4\text{mV} * 2 = 12.8\text{mV}$, as seen above)

Signal Swing(at transmitter)		250
Signal Swing(at receiver)		425
Gross Margin(at receiver)		212
Crosstalk		140
Reflections	0.11	46.6
Receiver offset+sensitivity		20
Bounded Noise		206.6
Net Margin		5.4
Gaussian Noise		10
VSNR		0.54
BER		8.60E-01

A. Source Termination

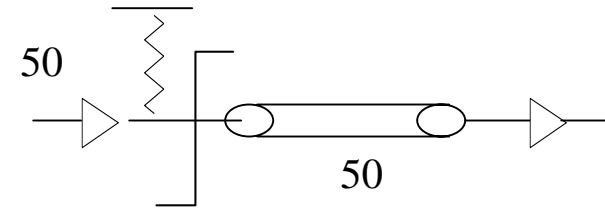

Reflections

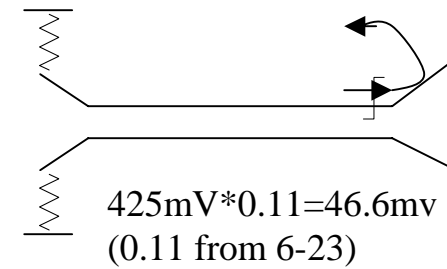

Signal Swing

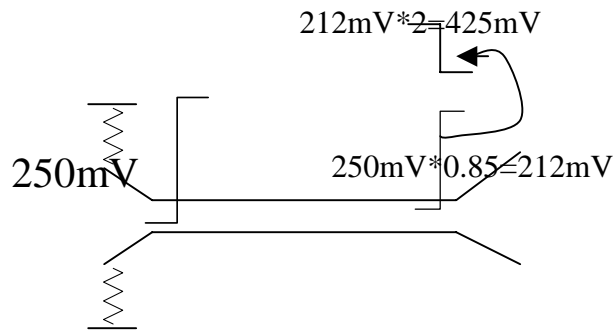

Crosstalk

